



Kit "F"

Multifunction scale, 2 terracotta bowls with stainless steel lid, 2 glass salt shakers, 2 stainless steel bottle holders

Equipped troughs accessories

Code: 8100 706



DETAILS

Equipped troughs accessories Multifunction kit

Type Standard

Dimensions 22 1/16" x 5 1/2"

Length 4 unit

Key to understanding the accessories The lengths of the channels and accessories are indicated in "units"; for the composition, the sum of the "units" of the accessories must be the same as the length in "units" of the channel.

Scale features

- Dimension 8 1/2" x 6 1/2" - Max capacity 5 kg
- Bluetooth connection to smartphone
- Free access to the smartapple app
- Database with more than 430 stored foods

TECHNICAL DATA

8100 706

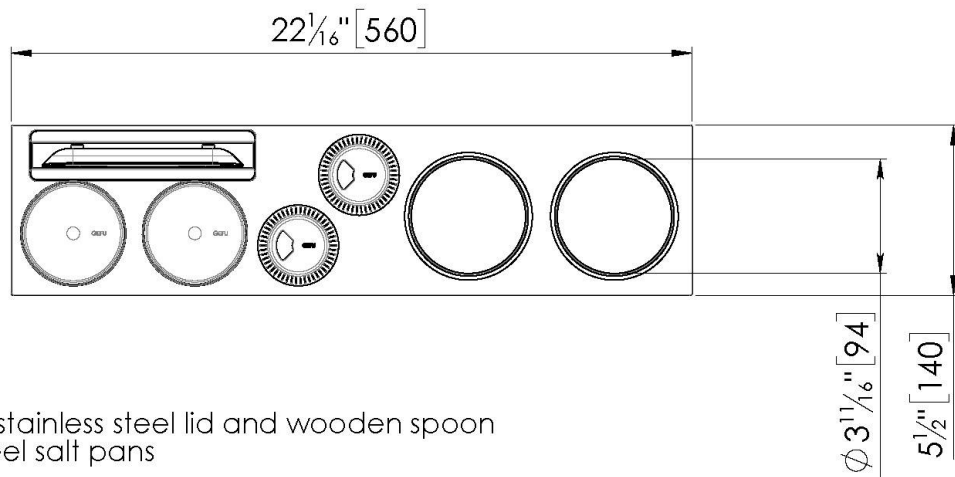
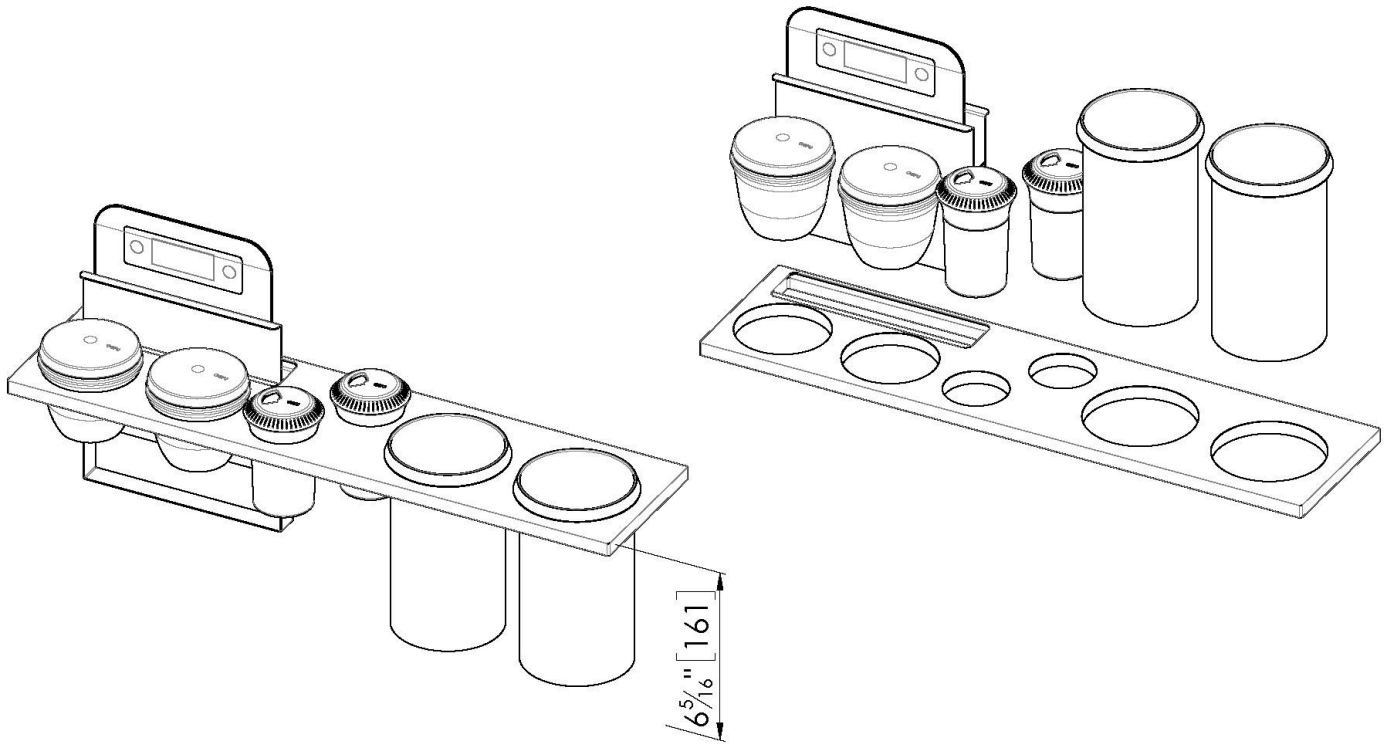

- 1 x black support
- 1 x balance
- 2 x terracotta bowl with stainless steel lid and wooden spoon
- 2 x glass and stainless steel salt pans
- 2 x bottle holder

ϕ 3 ¹/₁₆" [94]
5 ¹/₂" [140]

OPTIONAL ACCESSORIES



Knives-holder

8100 030